

Trinkwasserspeicher
 Domestic hot water tank
 Ballon eau chaude sanitaire
 Serbatoio di accumulo acqua calda sanitaria
 SF/C 200–2000



EN 12897
 EnEV 730.02
 ErP 812/2013
 ErP 814/2013
 SIA 385/1
 DIN 4753



1006-5752

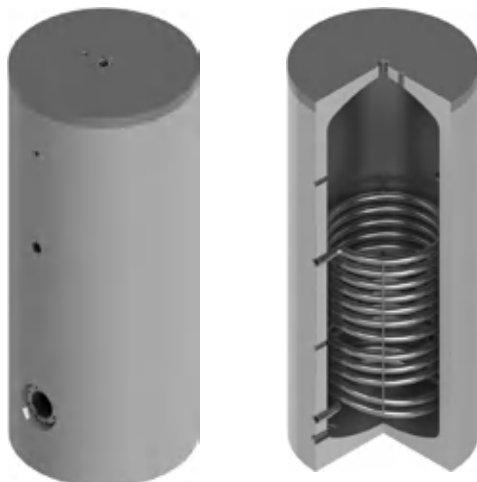

Bauart
 Design | Structure | Struttura

Die Speicher sind aus hochwertigem Edelstahl V4A gefertigt.
 Die Speicher werden nach EN 12897:2020 dimensioniert, gefertigt und zertifiziert.

EN The storage tanks are made from high quality stainless steel (V4A). The storage tanks are designed, manufactured and certified in accordance with EN 12897:2020.

FR Les ballons sont fabriqués en acier inoxydable au molybdène de grande qualité. Les ballons sont dimensionnés, fabriqués et certifiés selon la norme EN 12897:2020.

IT Gli accumulatori sono realizzati in pregiato acciaio inossidabile V4A. Gli accumulatori sono dimensionati, costruiti e certificati secondo la norma EN 12897:2020.

Betriebsdruck / Prüfdruck Operating pressure / test pressure Pression de service / Pression test Pressione d'esercizio / Pressione di collaudo	6 bar / 12 bar
Einsatzgebiet Application Application Applicazione	max. 95°C Cl ≤ 70 mg/l

Lieferumfang
 Delivery | Livraison | Consegna

Ersatzteile Spare parts Pièces détachées Ricambi	Art.Nr.													
		200	300	400	500	600	800	1000	1250	1500	1750	2000		
Thermometer (V4A) Thermometer (V4A) Thermomètre (V4A) Termometro (V4A)	100 mm	6001160100	1x	1x	1x	1x	1x							
	200 mm	6001160200						1x	1x	1x	1x	1x	1x	1x
Tauchhülse (V4A) Immersion sleeve (V4A) Manchon d'immersion (V4A) Manicotto ad immersione (V4A)	1000 mm	6001191000	1x	1x	1x	1x	1x	1x	1x	1x	1x	1x	1x	1x

**Schutz vor Korrosion****Anti-corrosion protection | Protection contre la corrosion | Protezione anticorrosiva**

Behälter vollständig tauchgebeizt und passiviert. Hochwertiger, dickwandiger Edelstahl V4A.

EN Water tanks completely pickled by immersion and passivated. High-quality stainless steel V4A with thick walls.

FR Réservoirs intégralement décapés par immersion et passivés. Tôle épaisse en acier inoxydable V4A haut de gamme.

IT Serbatoio interamente decapato a immersione e passivato. Pregiato acciaio inox V4A di notevole spessore.

Wärmetauscher**Heat exchanger | Échangeur de chaleur | Scambiatore di calore**

Ein eingeschweisster grossflächiger Wärmetauscher.

EN One welded large-surface heat exchanger.

FR Un échangeur de chaleur grande surface soudé.

IT Uno scambiatore di calore saldato di grande superficie.

Betriebsdruck / Prüfdruck Operating pressure / test pressure Pression de service / Pression test Pressione d'esercizio / Pressione di collaudo	6 bar / 12 bar
Einsatzgebiet Application Applicazione	max. 110°C

Isolierung**Insulation | Isolation | Isolamento****PUR-Hartschaum**

60 mm PUR-Hartschaum fix geschäumt. Skaimantel 5 mm mit Reissverschluss vormontiert, inklusive Rosetten und Abdeckhaube. Brandschutzklasse B2. Silber. Weitere Farben nach Absprache.

UltraShell

Mehrschicht-Isolierung aus 80 mm Hartschaum + 20 mm Faservlies. PS-Mantel und Hakenleiste, inklusive Rosetten und Abdeckhaube. Brandschutzklasse B2. Silber. Lose geliefert.

EN Rigid polyurethane foam (PUR)

60 mm rigid polyurethane foam. Skai jacket 5 mm with zip preassembled, including cover plates and hood. Fire-resistance rating B2. Silver. Other colours on request.

FR Mousse solidifiée PUR

60 mm de mousse dure PUR Enveloppe en skaï de 5 mm préinstallée avec fermeture à glissière, y compris rosettes et capot. Classe allemande de protection incendie B2. Argent. Autres couleurs après concertation.

IT Schiuma PUR rigida

60 mm di schiuma rigida di poliuretano fissa. Mantello in skaï da 5 mm pre-assemblato con cerniera, dotato di rosette e calotta di copertura. Classe di resistenza antincendio B2. Argent. Altri colori su richiesta.

UltraShell

Multilayer insulation made of 80 mm rigid foam + 20 mm fibre fleece. PS jacket and hook rack, including cover plates and hood. Fire-resistance rating B2. Silver. Supplied loose.

UltraShell

Isolation multicouche constituée de 80 mm de mousse dure + 20 mm de tissu fibreux. Enveloppe en PS équipée d'un support à crochets préinstallé, y compris rosettes et capot. Classe allemande de protection incendie B2. Argent. Livrée non montée.

UltraShell

Isolamento multistrato con 80 mm di schiuma rigida + 20 mm di tessuto non tessuto. Mantello in PS e barra con ganci, rosette e calotta di copertura incluse. Classe di resistenza antincendio B2. Argent. Consegna sfusa.

≤ 600 L

PUR (Polyurethane)
B2; $\lambda = 0.026 \text{ W/(mK)}$

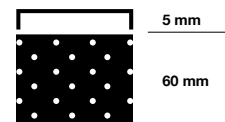

800 – 2000 L

UltraShell
B2; $\lambda = 0.0316 \text{ W/(mK)}$

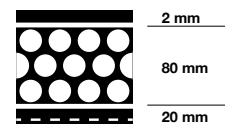

Trinkwasserspeicher
Domestic hot water tank
Ballon eau chaude sanitaire
Serbatoio di accumulo acqua calda sanitaria
SF/C 200–2000

Edelstahl
 Stainless steel | Acier inoxydable | Acciaio inossidabile

Typ SF/C		200	300	400	500	600	800	1000	1250	1500	1750	2000
Inhalt Capacity Contenance Contenuto	l	191	304	408	498	559	830	925	1226	1413	1728	1926
Ø mit Isolierung with insulation avec isolation con isolamento	mm	600	650	750	750	750	990	990	1100	1200	1300	1300
Ø ohne Isolierung without insulation sans isolation senza isolamento	mm	-	-	-	-	-	790	790	900	1000	1100	1100
Höhe mit Isolierung Height with insulation Hauteur avec isolation Altezza con isolamento	mm	1215	1570	1500	1800	2000	1990	2190	2240	2120	2150	2350
Kippmass Tilted dimension Cote de basculement Altezza in raddrizzamento	mm	1360	1710	1690	1960	2150	1990	2190	2260	2140	2200	2380
Einbringmass Delivery dimensions Cote de mise en place Ingombro	mm	600	650	750	750	750	790	790	900	1000	1100	1100
Betriebsdruck Heizung Heater operating pressure Pression de service du chauffage Pressione d'esercizio riscaldamento	bar	6	6	6	6	6	6	6	6	6	6	6
Betriebsdruck Wasser Water operating pressure Pression de service de l'eau Pressione d'esercizio acqua	bar	6	6	6	6	6	6	6	6	6	6	6
Prüfdruck Test pressure Pression test Pressione di collaudo	bar	12	12	12	12	12	12	12	12	12	12	12
max. Betriebstemperatur max. operating temperature Temp. de service max. Temperatura max. d'esercizio	°C	95	95	95	95	95	95	95	95	95	95	95
Gewicht Weight Poids Peso	kg	75	103	119	140	153	221	236	275	307	340	372
Art.Nr. Part no. Réf. Art.n.	100202...	0200	0300	0400	0500	0600	0800	1000	1250	1500	1750	2000
Isolierung Insulation Isolation Isolamento		60 mm fix eingeschäumt Fixed with foam Enrobage mousse fixe Schiuma rigida fissa					UltraShell 100					
Wärmeverlust Heat losses Pertesthermiques Perdita di calore	kWh/24h	1.01	1.44	1.69	1.95	2.05	3.29	3.45	3.64	3.84	4.05	4.42
	W	43	60	71	82	86	138	144	152	159	169	185
ErP-Klasse ErP class Classe ErP Classe ErP		A	B	B	B	B	C	C	C	C	C	C
Gewicht Weight Poids Peso	kg	-	-	-	-	-	35	40	45	50	55	60
Art.Nr. Part no. Réf. Art.n.	300102...	-	-	-	-	-	0809	1009	1259	1509	1759	2009



Typ SF/C		200	300	400	500	600	800	1000	1250	1500	1750	2000
Glattrohrwärmetauscher Heating coil Échangeurs de chaleur Serpentino	m ²	1.0	1.3	1.7	2.0	2.0	2.7	2.7	3.3	4.3	4.6	5.0
Inhalt Glattrohrwärmetauscher Heating coil capacity Contenance échangeurs de chaleur Con- tenuto serpentino	l	6.6	8.5	11.1	13.0	13.0	22.7	22.7	27.6	33.5	38.5	41.9
Durchflussmenge Throughput Débit Portata flusso	m ³ / h	1.7	2.2	2.9	3.3	3.3	4.5	4.5	5.5	7.2	7.7	8.4
Druckverlust Pressure loss Perte de charge Perdita di pressione	mbar	30	70	120	200	200	100	100	190	390	490	630
Dauerleistung Continuous output Régime permanent Potenza continua 10°C / 45°C / 80°C	l / h	479	622	813	1027	1027	1292	1292	1579	2058	2201	2393
max. Glattrohrwärmetauscherleistung max. heating coil output Puissance max. d'échangeurs de chaleur Potenza max. serpentino	kW	19.5	25.4	33.1	38.1	38.1	52.6	52.6	64.3	83.7	89.6	97.4

Trinkwasserspeicher
Domestic hot water tank
Ballon eau chaude sanitaire
Serbatoio di accumulo acqua calda sanitaria
SF/C 200-2000

Edelstahl
 Stainless steel | Acier inoxydable | Acciaio inossidabile

200 - 600

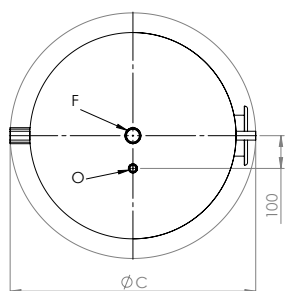
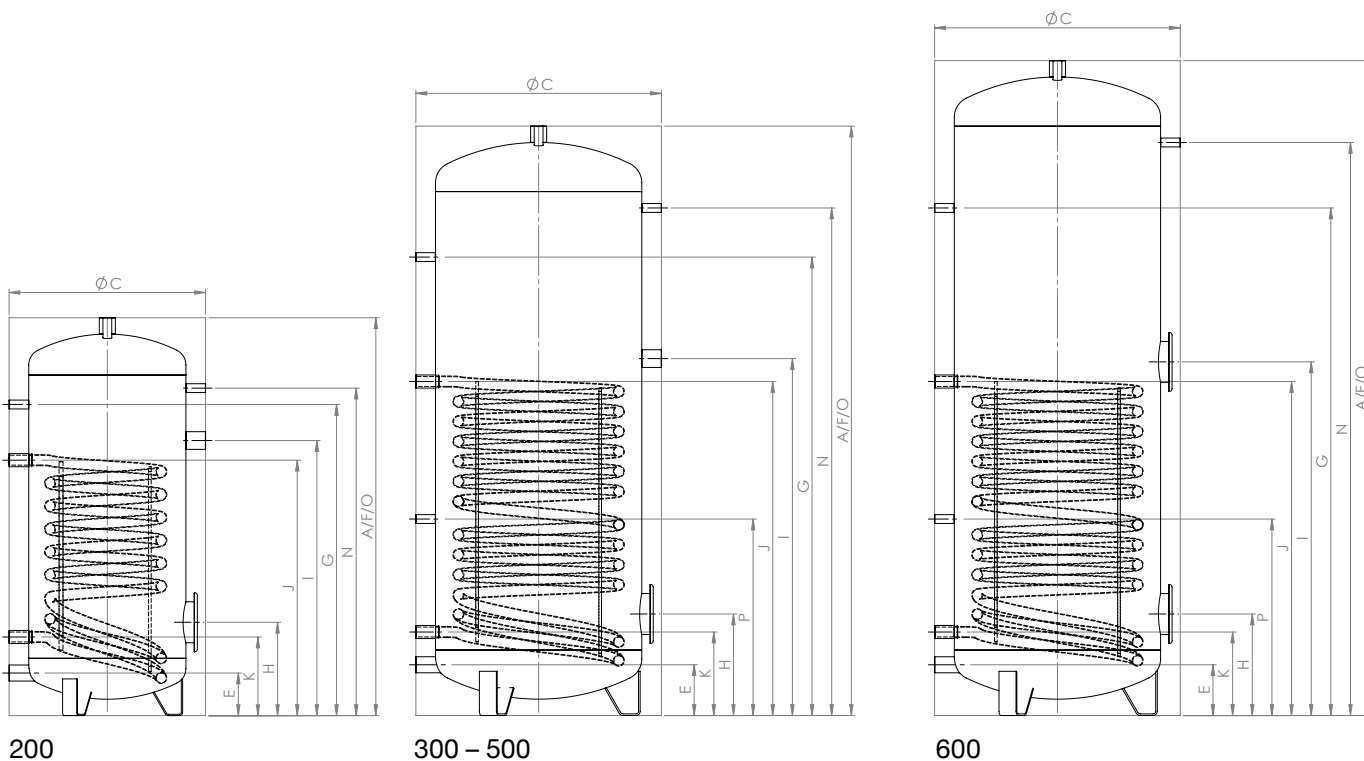

200 - 600



	Verwendung Usage Utilisation Uso	Dimension Dimension Dimension Dimensione	200	300	400	500	600
A	Höhe Height Hauteur Altezza	○ – mm	1215	1570	1500	1800	2000
C	Ø	○ – mm	600	650	750	750	750
E	Kaltwasser Cold water Eau froide Acqua fredda	⇕ – mm	130	140	155	155	155
		G" – mm	1 ¼"	1 ¼"	1 ¼"	1 ¼"	1 ¼"
F	Warmwasser Hot water Eau chaude Acqua calda	⇕ – mm	1215	1570	1500	1800	2000
		G" – mm	1 ¼"	1 ¼"	1 ¼"	1 ¼"	1 ¼"
G	Zirkulation Circulation Circulation Circolazione	⇕ – mm	950	1200	1150	1400	1550
		G" – mm	½"	½"	½"	½"	½"
H	Flansch unten Flange below Bride du bas Flangia inferiore	⇕ – mm	285	295	310	310	310
		Ø – mm	180/120	180/120	180/120	180/120	180/120
I	Flansch oben / Muffe E-Heizung Flange above / Sleeve electric heater Bride du haut / Manchon chauffage électrique Flangia superiore / Manicotto riscaldatore elettrico	⇕ – mm	840	910	920	1090	1080
		Ø – mm	1 ½"	1 ½"	1 ½"	1 ½"	180/120
J	VL Glattrohrwärmetauscher Heating coil Échangeurs de chaleur Serpentino	⇕ – mm	780	840	855	1020	1020
		G" – mm	1"	1"	1"	1"	1"
K	RL Glattrohrwärmetauscher Heating coil Échangeurs de chaleur Serpentino	⇕ – mm	240	240	255	255	255
		G" – mm	1"	1"	1"	1"	1"
N	Thermometer Thermometer Thermomètre Termometro	⇕ – mm	1000	1350	1250	1550	1750
		G" – mm	½"	½"	½"	½"	½"
O	Fühlerhülse Sensor sleeve Manchon de sonde Manicotto sensore	⇕ – mm	1215	1570	1500	1800	2000
		G" – mm	½"	½"	½"	½"	½"
P	Fühler Sensor Sonde Sensor	⇕ – mm	-	570	590	600	600
		G" – mm	-	½"	½"	½"	½"
	Max. Einbaulänge von Elektroheizungen Maximum installation length of electric heaters Longueur maximale d'installation des chauffages électriques Lunghezza massima di installazione dei riscaldatori elettrici	⇑ – mm	520	540	630	630	630
		⇓ – mm	410	450	560	560	560

Trinkwasserspeicher
Domestic hot water tank
Ballon eau chaude sanitaire
Serbatoio di accumulo acqua calda sanitaria
SF/C 200-2000

Edelstahl
Stainless steel | Acier inoxydable | Acciaio inossidabile

800 - 2000

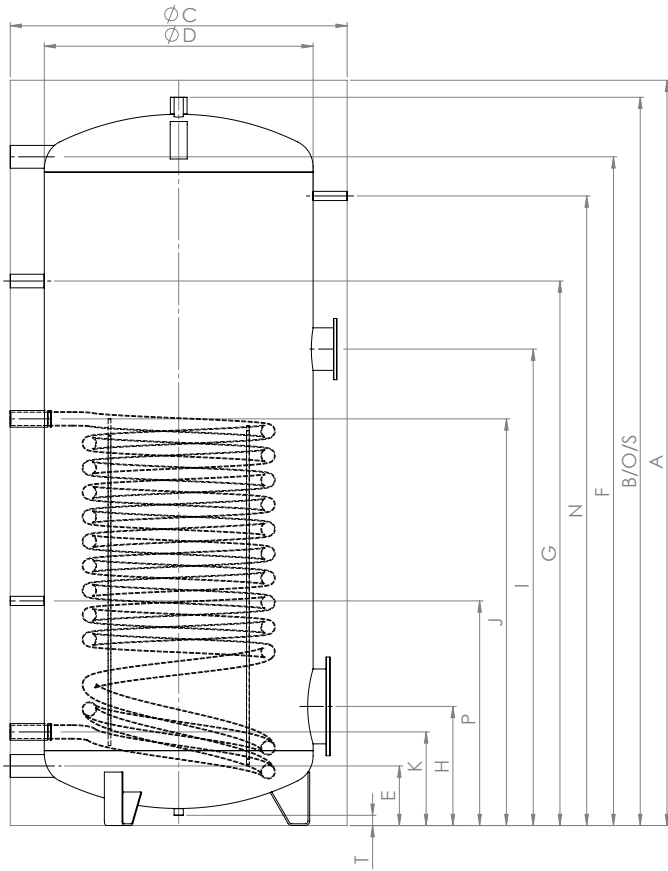

800 - 2000

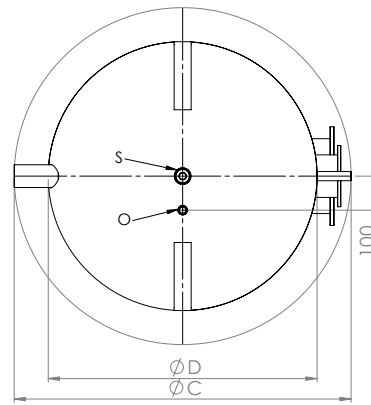

800 - 2000



	Verwendung Usage Utilisation Uso	Dimension Dimension Dimension Dimensione	800	1000	1250	1500	1750	2000
A	Höhe Height Hauteur Altezza	○ – mm	1990	2190	2240	2120	2150	2350
B		○ – mm	1940	2140	2190	2070	2100	2300
C	Ø	● – mm	990	990	1100	1200	1300	1300
D		○ – mm	790	790	900	1000	1100	1100
E	Kaltwasser Cold water Eau froide Acqua fredda	↕ – mm	175	175	200	220	235	235
		G" – mm	2"	2"	2"	2"	2"	2"
F	Warmwasser Hot water Eau chaude Acqua calda	↕ – mm	1765	1965	1990	1730	1730	1930
		G" – mm	2"	2"	2"	2"	2"	2"
G	Zirkulation Circulation Circulation Circolazione	↕ – mm	1400	1600	1600	1450	1450	1650
		G" – mm	1"	1"	1"	1"	1"	1"
H	Flansch unten Flange below Bride du bas Flangia inferiore	↕ – mm	350	350	400	470	480	480
		Ø – mm	290/220	290/220	290/220	290/220	290/220	290/220
I	Flansch oben Flange above Bride du haut Flangia superiore	↕ – mm	1400	1400	1300	1350	1350	1400
		Ø – mm	180/120	180/120	180/120	180/120	180/120	180/120
J	VL Glatrohrwärmetauscher Heating coil Échangeurs de chaleur Serpentino	↕ – mm	1195	1195	1220	1250	1250	1310
		G" – mm	1 ¼"	1 ¼"	1 ¼"	1 ¼"	1 ¼"	1 ¼"
K	RL Glatrohrwärmetauscher Heating coil Échangeurs de chaleur Serpentino	↕ – mm	275	275	320	360	360	360
		G" – mm	1 ¼"	1 ¼"	1 ¼"	1 ¼"	1 ¼"	1 ¼"
N	Thermometer Thermometer Thermomètre Termometro	↕ – mm	1650	1850	1900	1750	1750	1950
		G" – mm	½"	½"	½"	½"	½"	½"
O	Fühlerhülse Sensor sleeve Manchon de sonde Manicotto sensore	↕ – mm	1940	2140	2190	2070	2100	2300
		G" – mm	½"	½"	½"	½"	½"	½"
P	Fühler Sensor Sonde Sensor	↕ – mm	660	660	680	590	600	600
		G" – mm	½"	½"	½"	½"	½"	½"
S	Anschluss oben Connection top Lien ci-dessus Collegamento sopra	↕ – mm	1940	2140	2190	2070	2100	2300
		G" – mm	1 ¼"	1 ¼"	1 ¼"	1 ¼"	1 ¼"	1 ¼"
T	Bodenmuffe Ground fitting Manchon de fond Manicotto a pavimento	↕ – mm	30	30	30	30	30	30
		G" – mm	½"	½"	½"	1 ¼"	1 ¼"	1 ¼"
	Max. Einbaulänge von Elektroheizungen Maximum installation length of electric heaters Longueur maximale d'installation des chauffages électriques Lunghezza massima di installazione dei riscaldatori elettrici	↑ – mm	800	800	920	1020	1120	1120
		↓ – mm	690	690	770	870	970	970