

Trinkwasserspeicher  
Domestic hot water tank  
Ballon eau chaude sanitaire  
Serbatoio di accumulo acqua calda sanitaria  
DSFF/E 200–2000

DIN

EN 12897  
EnEV 730.02  
ErP 812/2013  
ErP 814/2013  
SIA 385/1  
DIN 4753



1006-5752

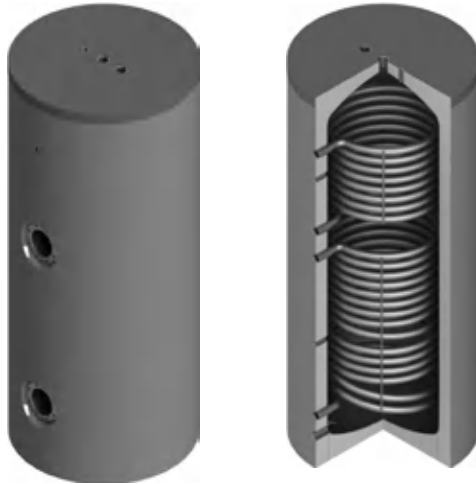

**Bauart**  
Design | Structure | Struttura

Die Speicher werden aus hochwertigem Stahl nach EN 10025:2019 gefertigt.  
Die Speicher werden nach EN 12897:2020 dimensioniert, gefertigt und zertifiziert.

**EN** The storage tanks are made from high quality steel in accordance with EN 10025:2019.  
The storage tanks are designed, manufactured and certified in accordance with EN 12897:2020.

**FR** Les ballons sont fabriqués en acier de grande qualité selon la norme EN 10025:2019.  
Les ballons sont dimensionnés, fabriqués et certifiés selon la norme EN 12897:2020.

**IT** Gli accumulatori sono realizzati in acciaio pregiato secondo la norma EN 10025:2019.  
Gli accumulatori sono dimensionati, costruiti e certificati secondo la norma EN 12897:2020.

<b>Betriebsdruck / Prüfdruck</b> Operating pressure / test pressure   Pression de service / Pression test   Pressione d'esercizio / Pressione di collaudo	6 bar / 12 bar
<b>Einsatzgebiet</b> Application   Application   Applicazione	max. 95°C ≥ 6°dH ≥ 11°FH

**Lieferumfang**  
Delivery | Livraison | Consegna

	Dimension Dimension Dimensione	Art.Nr.	200	300	400	500	600	800	1000	1250	1500	1750	2000
Thermometer (Messing) Thermometer (Brass) Thermomètre (Laiton) Termometro (Ottone)	100 mm	6001150100	1x	1x	1x	1x	1x						
	200 mm	6001150200						1x	1x	1x	1x	1x	1x
Tauchhülse (Messing) Thermowell (Brass) Doigt de gant (Laiton) Sonda a immersione (Ottone)	500 mm	6001180500	1x										
	800 mm	6001180800		1x	1x								
	1000 mm	6001181000				1x	1x	1x	1x	1x	1x	1x	1x
Magnesium Schutz- anode   Magnesium protection anode   Anode de protection en magnésium   Anodo protettivo di magnesio	520 mm	6001140520					1x	1x					
	750 mm	6001140750	1x	1x					1x			1x	1x
	1000 mm	6001141000			1x	1x	1x	1x	1x	2x	2x	2x	2x

**Schutz vor Korrosion****Anti-corrosion protection | Protection contre la corrosion | Protezione anticorrosiva**

Emallierung nach DIN 4753. Magnesium Schutzanode nach DIN 4753-3.  
Speicher mit separater Isolierung sind aussen grundiert.

**EN** Enamelling in accordance with DIN 4753. Magnesium protection anode in accordance with DIN 4753-3. Tanks with separate insulation are primed on the outside.

**FR** Émaillage conforme à la norme DIN 4753. Anode de protection en magnésium conforme à la norme DIN 4753-3. Les réservoirs avec isolation séparée sont apprêtés à l'extérieur.

**IT** Smaltatura secondo DIN 4753. Anodo protettivo di magnesio secondo DIN 4753-3. Gli accumulatori con isolamento separato vengono primerizzati all'esterno.

**Wärmetauscher****Heat exchanger | Échangeur de chaleur | Scambiatore di calore**

Zwei eingeschweisste grossflächige Wärmetauscher.

**EN** Two welded large-surface heat exchangers.

**FR** Deux échangeurs de chaleur grande surface soudés.

**IT** Due scambiatori di calore di grande superficie saldati.

<b>Betriebsdruck / Prüfdruck</b> Operating pressure / test pressure   Pression de service / Pression test   Pressione d'esercizio / Pressione di collaudo	6 bar / 12 bar
<b>Einsatzgebiet</b> Application   Applicazione	max. 110°C

**Isolierung****Insulation | Isolation | Isolamento****PUR-Hartschaum**

60 mm PUR-Hartschaum fix geschäumt. Skaimantel 5 mm mit Reissverschluss vormontiert, inklusive Rosetten und Abdeckhaube. Brandschutzklasse B2. Silber. Weitere Farben nach Absprache.

**UltraShell**

Mehrschicht-Isolierung aus 80 mm Hartschaum + 20 mm Faservlies. PS-Mantel und Hakenleiste, inklusive Rosetten und Abdeckhaube. Brandschutzklasse B2. Silber. Lose geliefert.

**EN Rigid polyurethane foam (PUR)**

60 mm rigid polyurethane foam. Skai jacket 5 mm with zip preassembled, including cover plates and hood. Fire-resistance rating B2. Silver. Other colours on request.

**FR Mousse solidifiée PUR**

60 mm de mousse dure PUR Enveloppe en skai de 5 mm préinstallée avec fermeture à glissière, y compris rosettes et capot. Classe allemande de protection incendie B2. Argent. Autres couleurs après concertation.

**IT Schiuma PUR rigida**

60 mm di schiuma rigida di poliuretano fissa. Mantello in skai da 5 mm pre-assemblato con cerniera, dotato di rosette e calotta di copertura. Classe di resistenza antincendio B2. Argent. Altri colori su richiesta.

**UltraShell**

Multilayer insulation made of 80 mm rigid foam + 20 mm fibre fleece. PS jacket and hook rack, including cover plates and hood. Fire-resistance rating B2. Silver. Supplied loose.

**UltraShell**

Isolation multicouche constituée de 80 mm de mousse dure + 20 mm de tissu fibreux. Enveloppe en PS équipée d'un support à crochets préinstallé, y compris rosettes et capot. Classe allemande de protection incendie B2. Argent. Livrée non montée.

**UltraShell**

Isolamento multistrato con 80 mm di schiuma rigida + 20 mm di tessuto non tessuto. Mantello in PS e barra con ganci, rosette e calotta di copertura incluse. Classe di resistenza antincendio B2. Argent. Consegna sfusa.

≤ 600 L  
PUR (Polyurethane)  
B2;  $\lambda = 0.026 \text{ W/(mK)}$

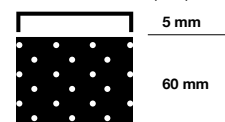

800 – 2000 L  
UltraShell  
B2;  $\lambda = 0.0316 \text{ W/(mK)}$

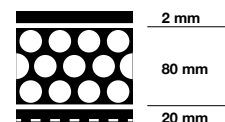

**Trinkwasserspeicher**  
**Domestic hot water tank**  
**Ballon eau chaude sanitaire**  
**Serbatoio di accumulo acqua calda sanitaria**  
**DSFF/E 200–2000**

**Emailliert**  
 Enamelled | Émaillés | Smaltato

Typ DSFF/E		200	300	400	500	600	800	1000	1250	1500	1750	2000	
Inhalt Capacity   Contenance   Contenuto	l	191	304	408	498	559	830	925	1226	1413	1728	1926	
Ø mit Isolierung with insulation   avec isolation   con isolamento	mm	600	650	750	750	750	990	990	1100	1200	1300	1300	
Ø ohne Isolierung without insulation   sans isolation   senza isolamento	mm	-	-	-	-	-	790	790	900	1000	1100	1100	
Höhe mit Isolierung Height with insulation   Hauteur avec isolation   Altezza con isolamento	mm	1215	1570	1500	1800	2000	1990	2190	2240	2120	2150	2350	
Kippmass Tilted dimension   Cote de basculement   Altezza in raddrizzamento	mm	1360	1710	1690	1960	2150	2020	2200	2270	2190	2250	2430	
Einbringmass Delivery dimensions   Cote de mise en place   Ingombro	mm	600	650	750	750	750	790	790	900	1000	1100	1100	
Betriebsdruck Heizung Heater operating pressure   Pression de service du chauffage   Pressione d'esercizio riscaldamento	bar	6	6	6	6	6	6	6	6	6	6	6	
Betriebsdruck Wasser Water operating pressure   Pression de service de l'eau   Pressione d'esercizio acqua	bar	6	6	6	6	6	6	6	6	6	6	6	
Prüfdruck Test pressure   Pression test   Pressione di collaudo	bar	12	12	12	12	12	12	12	12	12	12	12	
max. Betriebstemperatur max. operating temperature   Temp. de service max.   Temperatura max. d'esercizio	°C	95	95	95	95	95	95	95	95	95	95	95	
Gewicht Weight   Poids   Peso	kg	98	134	152	185	205	279	318	368	410	434	483	
Art.Nr. Part no.   Réf.   Art.n.	100103...	0200	0300	0400	0500	0600	0800	1000	1250	1500	1750	2000	
<b>Isolierung</b> Insulation   Isolation   Isolamento		<b>60 mm fix eingeschäumt Fixed with foam   Enrobage mousse fixe   Schiuma rigida fissa</b>					<b>UltraShell 100</b>						
Wärmeverlust Heat losses   Pertesthermiques   Perdita di calore	kWh/24h	1.01	1.44	1.69	1.95	2.05	3.29	3.45	3.64	3.84	4.05	4.42	
	W	43	60	71	82	86	138	144	152	159	169	185	
ErP-Klasse ErP class   Classe ErP   Classe ErP		A	B	B	B	B	C	C	C	C	C	C	
Gewicht Weight   Poids   Peso	kg	-	-	-	-	-	35	40	45	50	55	60	
Art.Nr. Part no.   Réf.   Art.n.	300103...	-	-	-	-	-	0809	1009	1259	1509	1759	2009	



Typ DSFF/E		200	300	400	500	600	800	1000	1250	1500	1750	2000
<b>Glattrohrwärmetauscher unten</b> Bottom heating coil   Échangeurs de chaleur bas   Serpentino inferiore	m <sup>2</sup>	1.0	1.6	1.9	2.4	2.4	3.0	3.7	4.1	4.4	5.0	5.4
<b>Inhalt Glattrohrwärmetauscher</b> Heating coil capacity   Contenance échangeurs de chaleur   Contenuto serpentino	l	5.8	9.9	12.4	15.5	15.5	24.2	24.2	27.0	28.8	32.9	35.3
<b>Durchflussmenge</b> Throughput   Débit   Portata flusso	m <sup>3</sup> / h	1.3	2.0	2.4	3.0	3.0	3.8	4.7	5.2	5.6	6.3	6.8
<b>Druckverlust</b> Pressure loss   Perte de charge   Perdita di pressione	mbar	30	70	90	230	230	90	160	160	180	270	360
<b>Dauerleistung</b> Continuous output   Régime permanent   Potenza continua 10°C / 45°C / 80°C	l / h	370	580	687	870	870	1085	1339	1484	1592	1808	1953
<b>max. Glattrohrwärmetauscherleistung</b> max. heating coil output   Puissance max. du échangeurs de chaleur   Potenza max. serpentino	kW	15.2	23.6	28.0	35.3	35.3	44.2	54.4	60.4	64.8	73.6	79.5
Typ DSFF/E		200	300	400	500	600	800	1000	1250	1500	1750	2000
<b>Glattrohrwärmetauscher oben</b> Top heating coil   Échangeurs de chaleur haut   Serpentino superiore	m <sup>2</sup>	0.5	0.9	0.8	1.3	1.9	1.8	2.2	2.5	2.5	2.9	2.9
<b>Inhalt Glattrohrwärmetauscher</b> Heating coil capacity   Contenance échangeurs de chaleur   Contenuto serpentino	l	2.9	5.7	4.5	8.5	12.3	15.0	18.6	20.9	20.9	24.3	24.3
<b>Durchflussmenge</b> Throughput   Débit   Portata flusso	m <sup>3</sup> / h	0.7	1.2	1.0	1.7	2.4	2.3	2.8	3.2	3.2	3.7	3.7
<b>Druckverlust</b> Pressure loss   Perte de charge   Perdita di pressione	mbar	20	30	30	40	90	30	40	50	50	80	80
<b>Dauerleistung</b> Continuous output   Régime permanent   Potenza continua 10°C / 45°C / 80°C	l / h	185	326	290	471	687	651	796	904	904	1049	1049
<b>max. Glattrohrwärmetauscherleistung</b> max. heating coil output   Puissance max. du échangeurs de chaleur   Potenza max. serpentino	kW	7.6	13.3	11.8	19.2	28.0	26.5	32.4	36.8	36.8	42.7	42.7

**Trinkwasserspeicher**  
**Domestic hot water tank**  
**Ballon eau chaude sanitaire**  
**Serbatoio di accumulo acqua calda sanitaria**  
**DSFF/E 200-2000**

**Emailliert**  
 Enamelled | Émaillés | Smaltato

200 - 600

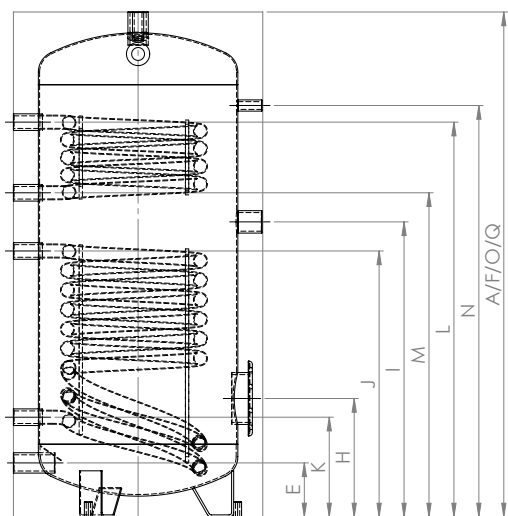

200

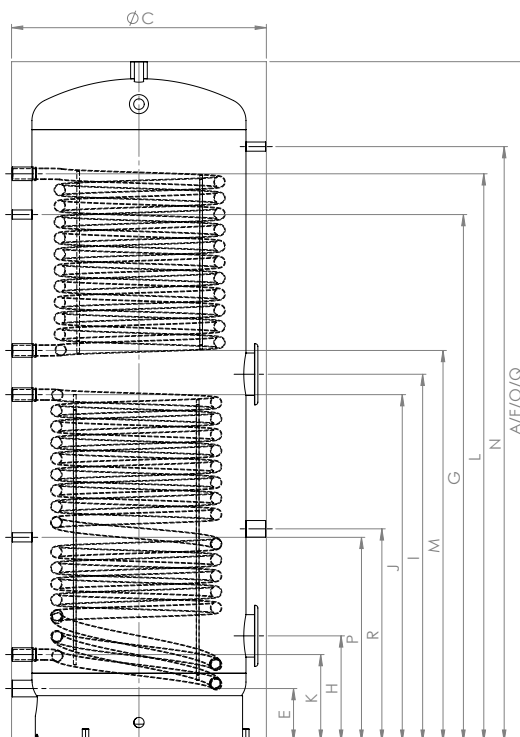
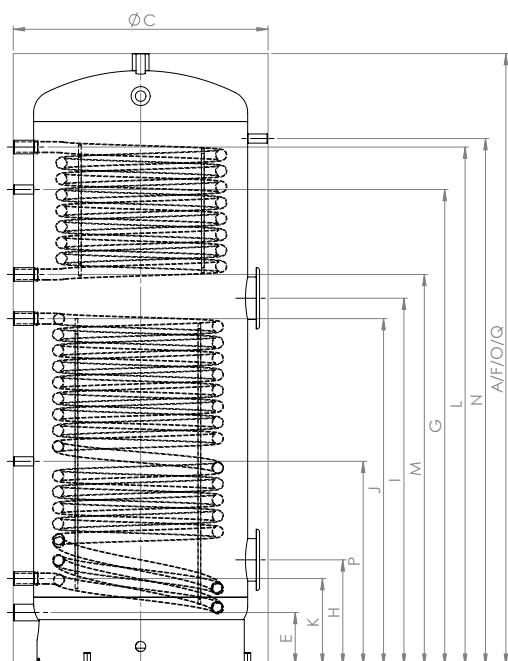

300 - 500

600

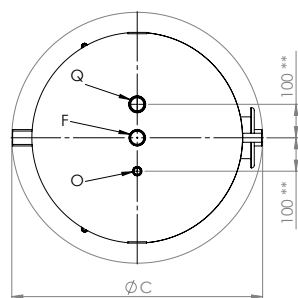

200 - 600



	Verwendung Usage Utilisation Uso	Dimension Dimension Dimension Dimensione	200	300	400	500	600
A	Höhe Height   Hauteur   Altezza	○ – mm	1215	1570	1500	1800	2000
C	Ø	○ – mm	600	650	750	750	750
E	Kaltwasser Cold water   Eau froide   Acqua fredda	⇕ – mm	130	140	155	155	155
		G" – mm	1 ¼"	1 ¼"	1 ¼"	1 ¼"	1 ¼"
F	Warmwasser Hot water   Eau chaude   Acqua calda	⇕ – mm	1215	1570	1500	1800	2000
		G" – mm	1 ¼"	1 ¼"	1 ¼"	1 ¼"	1 ¼"
G	Zirkulation Circulation   Circulation   Circolazione	⇕ – mm	-	1200	1150	1400	1550
		G" – mm	-	½"	½"	½"	½"
H	Flansch unten Flange below   Bride du bas   Flangia inferiore	⇕ – mm	285	295	310	310	310
		Ø – mm	180/120	180/120	180/120	180/120	180/120
I	Flansch oben Flange above   Bride du haut   Flangia superiore	⇕ – mm	710	920	930	1080	1080
		Ø – mm	1 ½"	180/120	180/120	180/120	180/120
J	VL Glattröhrwärmetauscher unten Bottom heating coil   Échangeurs de chaleur bas   Serpentino inferiore	⇕ – mm	640	840	855	1020	1020
		G" – mm	1"	1"	1"	1"	1"
K	RL Glattröhrwärmetauscher unten Bottom heating coil   Échangeurs de chaleur bas   Serpentino inferiore	⇕ – mm	240	240	255	255	255
		G" – mm	1"	1"	1"	1"	1"
L	VL Glattröhrwärmetauscher oben Top heating coil   Échangeurs de chaleur haut   Serpentino superiore	⇕ – mm	950	1330	1235	1525	1670
		G" – mm	1"	1"	1"	1"	1"
M	RL Glattröhrwärmetauscher oben Top heating coil   Échangeurs de chaleur haut   Serpentino superiore	⇕ – mm	780	1000	1000	1150	1150
		G" – mm	1"	1"	1"	1"	1"
N	Thermometer Thermometer   Thermomètre   Termometro	⇕ – mm	990	1350	1250	1550	1750
		G" – mm	½"	½"	½"	½"	½"
O	Fühlerhülse Sensor sleeve   Manchon de sonde   Manicotto sensore	⇕ – mm	1215	1570	1500	1800	2000
		G" – mm	½"	½"	½"	½"	½"
P	Fühler Sensor   Sonde   Sensor	⇕ – mm	-	570	590	600	600
		G" – mm	-	½"	½"	½"	½"
Q	Magnesiumanode Magnesium anode   Anode de magnésium   Anodo in magnesio	⇕ – mm	1215	1570	1500	1800	2000
		G" – mm	1 ¼"	1 ¼"	1 ¼"	1 ¼"	1 ¼"
R	Magnesiumanode Magnesium anode   Anode de magnésium   Anodo in magnesio	⇕ – mm	-	-	-	-	625
		G" – mm	-	-	-	-	1 ¼"
	Max. Einbaulänge von Elektroheizungen Maximum installation length of electric heaters   Longueur maximale d'installation des chauffages électriques   Lunghezza massima di installazione dei riscaldatori elettrici	↑ – mm	520	540	630	630	630
		↓ – mm	410	450	560	560	560

Trinkwasserspeicher  
 Domestic hot water tank  
 Ballon eau chaude sanitaire  
 Serbatoio di accumulo acqua calda sanitaria  
 DSFF/E 200–2000

Emailliert  
 Enamelled | Émaillés | Smaltato

800 – 2000

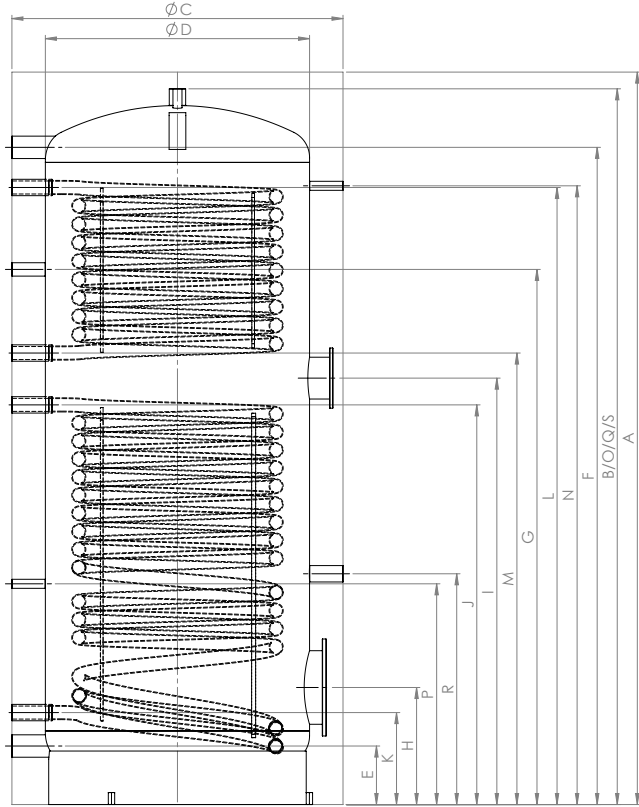

800 – 2000

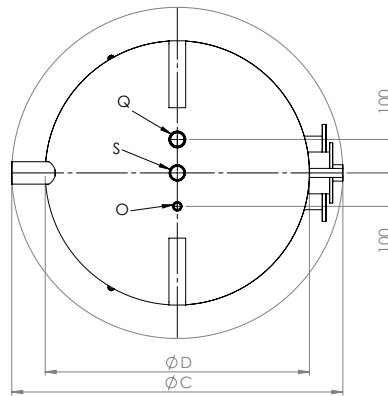

800 – 2000

- \* ACHTUNG: Magnesium Schutzanode
- \* ATTENTION Magnesium anode
- \* ATTENTION Anode de magnésium
- \* ATTENZIONE Anodo in magnesio



	Verwendung Usage Utilisation Uso	Dimension Dimension Dimension Dimensione	800	1000	1250	1500	1750	2000
A	Höhe Height   Hauteur   Altezza	⊙ - mm	1990	2190	2240	2120	2150	2350
B		○ - mm	1940	2140	2190	2070	2100	2300
C	∅	⊙ - mm	990	990	1100	1200	1300	1300
D		○ - mm	790	790	900	1000	1100	1100
E	Kaltwasser Cold water   Eau froide   Acqua fredda	⇕ - mm	175	175	200	220	235	235
		G"	2"	2"	2"	2"	2"	2"
F	Warmwasser Hot water   Eau chaude   Acqua calda	⇕ - mm	1765	1965	1990	1730	1730	1930
		G"	2"	2"	2"	2"	2"	2"
G	Zirkulation Circulation   Circulation   Circolazione	⇕ - mm	1400	1600	1600	1450	1400	1650
		G"	1"	1"	1"	1"	1"	1"
H	Flansch unten Flange below   Bride du bas   Flangia inferiore	⇕ - mm	350	350	400	470	480	480
		∅ - mm	290/220	290/220	290/220	290/220	290/220	290/220
I	Flansch oben Flange above   Bride du haut   Flangia superiore	⇕ - mm	1120	1275	1300	1090	1140	1240
		∅ - mm	180/120	180/120	180/120	180/120	180/120	180/120
J	VL Glattröhrwärmetauscher unten Bottom heating coil   Échangeurs de chaleur bas   Serpentino inferiore	⇕ - mm	1045	1195	1220	1020	1070	1130
		G"	1 ¼"	1 ¼"	1 ¼"	1 ¼"	1 ¼"	1 ¼"
K	RL Glattröhrwärmetauscher unten Bottom heating coil   Échangeurs de chaleur bas   Serpentino inferiore	⇕ - mm	275	275	320	360	360	360
		G"	1 ¼"	1 ¼"	1 ¼"	1 ¼"	1 ¼"	1 ¼"
L	VL Glattröhrwärmetauscher oben Top heating coil   Échangeurs de chaleur haut   Serpentino superiore	⇕ - mm	1580	1845	1880	1600	1620	1790
		G"	1 ¼"	1 ¼"	1 ¼"	1 ¼"	1 ¼"	1 ¼"
M	RL Glattröhrwärmetauscher oben Top heating coil   Échangeurs de chaleur haut   Serpentino superiore	⇕ - mm	1195	1350	1380	1160	1200	1350
		G"	1 ¼"	1 ¼"	1 ¼"	1 ¼"	1 ¼"	1 ¼"
N	Thermometer Thermometer   Thermomètre   Termometro	⇕ - mm	1650	1850	1900	1750	1750	1950
		G"	½"	½"	½"	½"	½"	½"
O	Fühlerhülse Sensor sleeve   Manchon de sonde   Manicotto sensore	⇕ - mm	1940	2140	2190	2070	2100	2300
		G"	½"	½"	½"	½"	½"	½"
P	Fühler Sensor   Sonde   Sensor	⇕ - mm	660	660	680	590	600	600
		G"	½"	½"	½"	½"	½"	½"
Q	Magnesiumanode Magnesium anode   Anode de magnésium   Anodo in magnesio	⇕ - mm	1940	2140	2190	2070	2100	2300
		G"	1 ¼"	1 ¼"	1 ¼"	1 ¼"	1 ¼"	1 ¼"
R	Magnesiumanode Magnesium anode   Anode de magnésium   Anodo in magnesio	⇕ - mm	690	690	710	800	810	820
		G"	1 ¼"	1 ¼"	1 ¼"	1 ¼"	1 ¼"	1 ¼"
S	Anschluss oben Connection top   Lien ci-dessus   Collegamento sopra	⇕ - mm	1940	2140	2190	2070	2100*	2300*
		G"	1 ¼"	1 ¼"	1 ¼"	1 ¼"	1 ¼"	1 ¼"
	Max. Einbaulänge von Elektroheizungen Maximum installation length of electric heaters   Longueur maximale d'installation des chauffages électriques   Lunghezza massima di installazione dei riscaldatori elettrici	⇑ - mm	800	800	920	1020	1120	1120
		⇓ - mm	690	690	770	870	970	970

