

**Trinkwasserspeicher für Wärmepumpe**  
**Domestic hot water tank for heat pump**  
**Ballon eau chaude sanitaire pour pompe à chaleur**  
**Serbatoio di accumulo acqua calda sanitaria per pompa di calore**  
**WPS/E 300 – 2000**

**DIN**

EN 12897  
 EnEV 730.02  
 ErP 812/2013  
 ErP 814/2013  
 SIA 385/1  
 DIN 4753



1006-5752

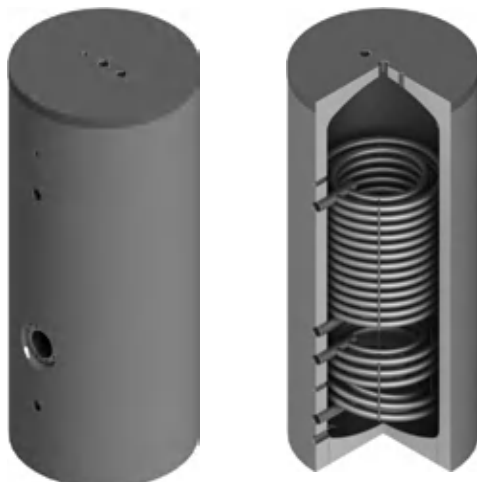

**Bauart**  
Design | Structure | Struttura

Die Speicher werden aus hochwertigem Stahl nach EN 10025:2019 gefertigt.  
 Die Speicher werden nach EN 12897:2020 dimensioniert, gefertigt und zertifiziert.

**EN** The storage tanks are made from high quality steel in accordance with EN 10025:2019.  
 The storage tanks are designed, manufactured and certified in accordance with EN 12897:2020.

**FR** Les ballons sont fabriqués en acier de grande qualité selon la norme EN 10025:2019.  
 Les ballons sont dimensionnés, fabriqués et certifiés selon la norme EN 12897:2020.

**IT** Gli accumulatori sono realizzati in acciaio pregiato secondo la norma EN 10025:2019.  
 Gli accumulatori sono dimensionati, costruiti e certificati secondo la norma EN 12897:2020.

<b>Betriebsdruck / Prüfdruck</b> Operating pressure / test pressure   Pression de service / Pression test   Pressione d'esercizio / Pressione di collaudo	6 bar / 12 bar
<b>Einsatzgebiet</b> Application   Application   Applicazione	max. 95°C ≥ 6°dH ≥ 11°fH

**Lieferumfang**  
Delivery | Livraison | Consegna

	Dimension Dimension Dimension Dimensione	Art.Nr.	300*	400	500	600	800	1000	1250	1500	1750	2000
<b>Thermometer (Messing)</b> Thermometer (Brass)   Thermomètre (Laiton)   Termometro (Ottone)	100 mm	6001150100	1x	1x	1x	1x						
	200 mm	6001150200					1x	1x	1x	1x	1x	1x
<b>Tauchhülse (Messing)</b> Thermowell (Brass)   Doigt de gant (Laiton)   Sonda a immersione (Ottone)	800 mm	6001180800	1x	1x	1x	1x						
	1000 mm	6001181000					1x	1x	1x	1x	1x	1x
<b>Magnesium Schutzanode</b> Magnesium protection anode   Anode de protection en magnésium   Anodo protettivo di magnesio	520 mm	6001140520		2x	1x	1x			1x	1x		
	750 mm	6001140750						1x				
	1000 mm	6001141000	1x		1x	1x	2x	1x	2x	2x	3x	3x

\* Produktion auf Anfrage  
 Production on Request | Production à la demande | Produzione su richiesta

**Schutz vor Korrosion****Anti-corrosion protection | Protection contre la corrosion | Protezione anticorrosiva**

Emallierung nach DIN 4753. Magnesium Schutzanode nach DIN 4753-3.  
Speicher mit separater Isolierung sind aussen grundiert.

**EN** Enamelling in accordance with DIN 4753. Magnesium protection anode in accordance with DIN 4753-3.  
Tanks with separate insulation are primed on the outside.

**FR** Émaillage conforme à la norme DIN 4753. Anode de protection en magnésium conforme à la norme DIN 4753-3. Les réservoirs avec isolation séparée sont apprêtés à l'extérieur.

**IT** Smaltatura secondo DIN 4753. Anodo protettivo di magnesio secondo DIN 4753-3. Gli accumulatori con isolamento separato vengono primerizzati all'esterno.

**Wärmetauscher****Heat exchanger | Échangeur de chaleur | Scambiatore di calore**

Zwei eingeschweisste grossflächige Wärmetauscher.

**EN** Two welded large-surface heat exchangers.

**FR** Deux échangeurs de chaleur grande surface soudés.

**IT** Due scambiatori di calore di grande superficie saldati.

<b>Betriebsdruck / Prüfdruck</b> Operating pressure / test pressure   Pression de service / Pression test   Pressione d'esercizio / Pressione di collaudo	6 bar / 12 bar
<b>Einsatzgebiet</b> Application   Applicazione	max. 110°C

**Isolierung****Insulation | Isolation | Isolamento****PUR-Hartschaum**

60 mm PUR-Hartschaum fix geschäumt. Skaimantel 5 mm mit Reissverschluss vormontiert, inklusive Rosetten und Abdeckhaube. Brandschutzklasse B2. Silber. Weitere Farben nach Absprache.

**UltraShell**

Mehrschicht-Isolierung aus 80 mm Hartschaum + 20 mm Faservlies. PS-Mantel und Hakenleiste, inklusive Rosetten und Abdeckhaube. Brandschutzklasse B2. Silber. Lose geliefert.

**EN Rigid polyurethane foam (PUR)**

60 mm rigid polyurethane foam. Skai jacket 5 mm with zip preassembled, including cover plates and hood. Fire-resistance rating B2. Silver. Other colours on request.

**FR Mousse solidifiée PUR**

60 mm de mousse dure PUR Enveloppe en skai de 5 mm préinstallée avec fermeture à glissière, y compris rosettes et capot. Classe allemande de protection incendie B2. Argent. Autres couleurs après concertation.

**IT Schiuma PUR rigida**

60 mm di schiuma rigida di poliuretano fissa. Mantello in skai da 5 mm pre-assemblato con cerniera, dotato di rosette e calotta di copertura. Classe di resistenza antincendio B2. Argent. Altri colori su richiesta.

**UltraShell**

Multilayer insulation made of 80 mm rigid foam + 20 mm fibre fleece. PS jacket and hook rack, including cover plates and hood. Fire-resistance rating B2. Silver. Supplied loose.

**UltraShell**

Isolation multicouche constituée de 80 mm de mousse dure + 20 mm de tissu fibreux. Enveloppe en PS équipée d'un support à crochets préinstallé, y compris rosettes et capot. Classe allemande de protection incendie B2. Argent. Livrée non montée.

**UltraShell**

Isolamento multistrato con 80 mm di schiuma rigida + 20 mm di tessuto non tessuto. Mantello in PS e barra con ganci, rosette e calotta di copertura incluse. Classe di resistenza antincendio B2. Argent. Consegna sfusa.

≤ 600 L

PUR (Polyurethane)  
B2;  $\lambda = 0.026 \text{ W/(mK)}$

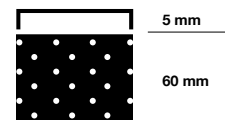

800 – 2000 L

UltraShell  
B2;  $\lambda = 0.0316 \text{ W/(mK)}$

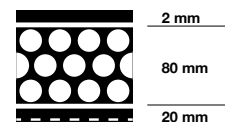

**Trinkwasserspeicher für Wärmepumpe**  
**Domestic hot water tank for heat pump**  
**Ballon eau chaude sanitaire pour pompe à chaleur**  
**Serbatoio di accumulo acqua calda sanitaria per pompa di calore**  
**WPS/E 300 – 2000**

**Emailliert**  
**Enamelled | Émaillés | Smaltato**

Typ WPS/E		300*	400	500	600	800	1000	1250	1500	1750	2000
Inhalt Capacity   Contenance   Contenuto	l	304	408	498	559	830	925	1226	1413	1728	1926
Ø mit Isolierung with insulation   avec isolation   con isolamento	mm	650	750	750	750	990	990	1100	1200	1300	1300
Ø ohne Isolierung without insulation   sans isolation   senza isolamento	mm	-	-	-	-	790	790	900	1000	1100	1100
Höhe mit Isolierung Height with insulation   Hauteur avec isolation   Altezza con isolamento	mm	1570	1500	1800	2000	1990	2190	2240	2120	2150	2350
Kippmass Tilted dimension   Cote de basculement   Altezza in raddrizzamento	mm	1710	1690	1960	2150	2020	2200	2270	2190	2250	2430
Einbringmass Delivery dimensions   Cote de mise en place   Ingombro	mm	650	750	750	750	790	790	900	1000	1100	1100
Betriebsdruck Heizung Heater operating pressure   Pression de service du chauffage   Pressione d'esercizio riscaldamento	bar	6	6	6	6	6	6	6	6	6	6
Betriebsdruck Wasser Water operating pressure   Pression de service de l'eau   Pressione d'esercizio acqua	bar	6	6	6	6	6	6	6	6	6	6
Prüfdruck Test pressure   Pression test   Pressione di collaudo	bar	12	12	12	12	12	12	12	12	12	12
max. Betriebstemperatur max. operating temperature   Temp. de service max.   Temperatura max. d'esercizio	°C	95	95	95	95	95	95	95	95	95	95
Gewicht Weight   Poids   Peso	kg	120	189	216	261	312	368	446	489	515	603
Art.Nr. Part no.   Réf.   Art.n.	100105...	0300	0400	0500	0600	0800	1000	1250	1500	1750	2000
<b>Isolierung</b> Insulation   Isolation   Isolamento		<b>60 mm</b> <b>fix eingeschäumt</b> Fixed with foam   Enrobage mousse fixe   Schiuma rigida fissa				<b>UltraShell 100</b>					
Wärmeverlust Heat losses   Pertesthermiques   Perdita di calore	kWh/24h	1.44	1.69	1.95	2.05	3.29	3.45	3.64	3.84	4.05	4.42
	W	60	71	82	86	138	144	152	159	169	185
ErP-Klasse ErP class   Classe ErP   Classe ErP		B	B	B	B	C	C	C	C	C	C
Gewicht Weight   Poids   Peso	kg	-	-	-	-	35	40	45	50	55	60
Art.Nr. Part no.   Réf.   Art.n.	300105...	-	-	-	-	0809	1009	1259	1509	1759	2009

\* Produktion auf Anfrage  
 Production on Request | Production à la demande | Produzione su richiesta

**WPS/E 300 – 2000**

Typ WPS/E		300*	400	500	600	800	1000	1250	1500	1750	2000
<b>Glattrohrwärmetauscher unten</b> Bottom heating coil   Échangeurs de chaleur bas   Serpentino inferiore	m <sup>2</sup>	1.2	1.2	1.5	1.8	2.2	3.5	3.3	3.4	3.9	5.2
<b>Inhalt Glattrohrwärmetauscher</b> Heating coil capacity   Contenance échangeurs de chaleur   Contenuto serpentino	l	6.5	7.8	9.8	11.8	14.4	22.3	29.1	30.0	34.4	45.9
<b>Durchflussmenge</b> Throughput   Débit   Portata flusso	m <sup>3</sup> / h	1.3	1.5	1.9	2.3	2.8	4.4	4.2	4.3	4.9	6.6
<b>Druckverlust</b> Pressure loss   Perte de charge   Perdita di pressione	mbar	20	20	40	60	70	100	30	30	40	100
<b>Dauerleistung</b> Continuous output   Régime permanent   Potenza continua 10°C / 45°C / 80°C	l / h	363	435	543	652	796	1266	1194	1231	1410	1882
<b>max. Glattrohrwärmetauscherleistung</b> max. heating coil output   Puissance max. du échangeurs de chaleur   Potenza max. serpentino	kW	14.8	17.7	22.1	26.6	32.4	51.5	48.6	50.1	57.4	76.6
Typ WPS/E		300*	400	500	600	800	1000	1250	1500	1750	2000
<b>Glattrohrwärmetauscher oben</b> Top heating coil   Échangeurs de chaleur haut   Serpentino superiore	m <sup>2</sup>	2.5	2.9	3.8	5.3	5.2	6.0	7.7	7.3	7.8	9.1
<b>Inhalt Glattrohrwärmetauscher</b> Heating coil capacity   Contenance échangeurs de chaleur   Contenuto serpentino	l	15.9	18.4	24.1	34.7	34.0	39.2	67.9	64.4	68.8	80.2
<b>Durchflussmenge</b> Throughput   Débit   Portata flusso	m <sup>3</sup> / h	1.1	1.3	1.6	2.3	2.3	2.6	3.3	3.1	3.4	3.8
<b>Druckverlust</b> Pressure loss   Perte de charge   Perdita di pressione	mbar	20	20	20	30	30	30	30	30	30	30
<b>Dauerleistung</b> Continuous output   Régime permanent   Potenza continua 10°C / 45°C / 50°C	l / h	159	184	243	320	320	370	466	442	479	540
<b>max. Glattrohrwärmetauscherleistung</b> max. heating coil output   Puissance max. du échangeurs de chaleur   Potenza max. serpentino	kW	6.3	7.5	9.5	13.0	13.0	15.0	19.0	18.0	19.5	22.0
<b>Durchflussmenge</b> Throughput   Débit   Portata flusso	m <sup>3</sup> / h	3.2	3.7	4.8	6.7	6.5	7.6	9.8	9.3	9.9	11.5
<b>Druckverlust</b> Pressure loss   Perte de charge   Perdita di pressione	mbar	40	50	100	260	240	380	330	280	340	530
<b>Dauerleistung</b> Continuous output   Régime permanent   Potenza continua 10°C / 45°C / 80°C	l / h	904	1049	1377	2062	1881	2171	2786	2641	2823	3293
<b>max. Glattrohrwärmetauscherleistung</b> max. heating coil output   Puissance max. d'échangeurs de chaleur   Potenza max. serpentino	kW	36.7	42.6	56.0	78.0	76.6	88.4	113.4	107.5	114.9	134.0

**Trinkwasserspeicher für Wärmepumpe**  
**Domestic hot water tank for heat pump**  
**Ballon eau chaude sanitaire pour pompe à chaleur**  
**Serbatoio di accumulo acqua calda sanitaria per pompa di calore**  
**WPS/E 300 – 2000**

**Emailliert**  
 Enamelled | Émaillés | Smaltato

300 – 600

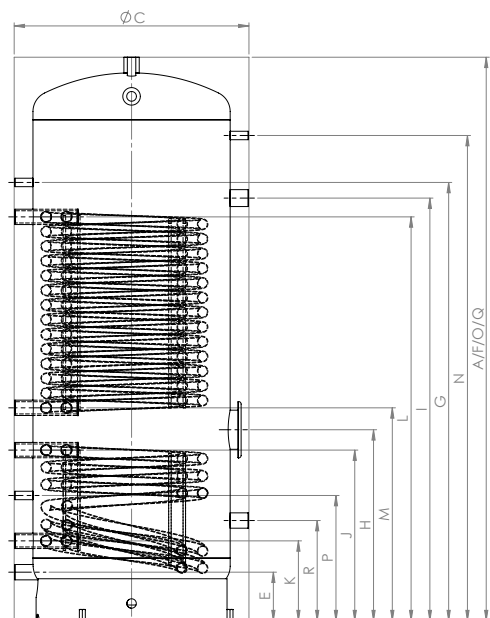

300 – 500

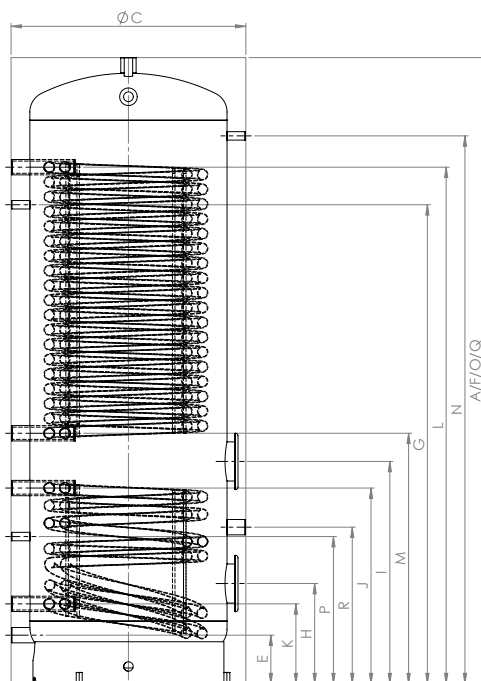

600

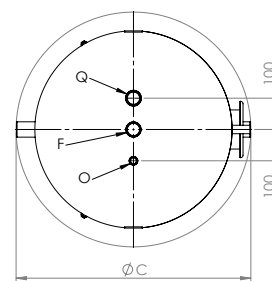

300 – 600



	Verwendung Usage Utilisation Uso	Dimension Dimension Dimension Dimensione	300*	400	500	600
A	Höhe Height   Hauteur   Altezza	○ – mm	1570	1500	1800	2000
C	Ø	○ – mm	650	750	750	750
E	Kaltwasser Cold water   Eau froide   Acqua fredda	⇄ – mm	140	155	155	155
		G" – mm	1 ¼"	1 ¼"	1 ¼"	1 ¼"
F	Warmwasser Hot water   Eau chaude   Acqua calda	⇄ – mm	1570	1500	1800	2000
		G" – mm	1 ¼"	1 ¼"	1 ¼"	1 ¼"
G	Zirkulation Circulation   Circulation   Circolazione	⇄ – mm	1020	1200	1400	1530
		G" – mm	½"	½"	½"	½"
H	Flansch unten Flange below   Bride du bas   Flangia inferiore	⇄ – mm	560	550	610	320
		Ø – mm	180/120	180/120	180/120	180/120
I	Flansch oben / Muffe E-Heizung Flange above / Sleeve heater   Bride du haut / Manchon chauffage   Flangia superiore / Manicotto riscaldatore	⇄ – mm	1200	-	1350	710
		Ø – mm	1 ¼"	-	1 ½"	180/120
J	VL Glattrohrwärmetauscher unten Bottom heating coil   Échangeurs de chaleur bas   Serpentino inferiore	⇄ – mm	475	490	545	625
		G" – mm	1 ¼"	1 ¼"	1 ¼"	1 ¼"
K	RL Glattrohrwärmetauscher unten Bottom heating coil   Échangeurs de chaleur bas   Serpentino inferiore	⇄ – mm	240	255	255	255
		G" – mm	1 ¼"	1 ¼"	1 ¼"	1 ¼"
L	VL Glattrohrwärmetauscher oben Top heating coil   Échangeurs de chaleur haut   Serpentino superiore	⇄ – mm	1135	1115	1290	1650
		v – G" – mm	1 ¼"	1 ¼"	1 ¼"	1 ¼"
M	RL Glattrohrwärmetauscher oben Top heating coil   Échangeurs de chaleur haut   Serpentino superiore	⇄ – mm	640	620	680	800
		G" – mm	1 ¼"	1 ¼"	1 ¼"	1 ¼"
N	Thermometer Thermometer   Thermomètre   Termometro	⇄ – mm	1350	1250	1550	1750
		G" – mm	½"	½"	½"	½"
O	Fühlerhülse Sensor sleeve   Manchon de sonde   Manicotto sensore	⇄ – mm	1570	1500	1800	2000
		G" – mm	½"	½"	½"	½"
P	Fühler Sensor   Sonde   Sensor	⇄ – mm	390	400	400	470
		G" – mm	½"	½"	½"	½"
Q	Magnesiumanode Magnesium anode   Anode de magnésium   Anodo in magnesio	⇄ – mm	1570	1500	1800	2000
		G" – mm	1 ¼"	1 ¼"	1 ¼"	1 ¼"
R	Magnesiumanode Magnesium anode   Anode de magnésium   Anodo in magnesio	⇄ – mm	-	320	320	500
		G" – mm	-	1 ¼"	1 ¼"	1 ¼"
	Max. Einbaulänge von Elektroheizungen Maximum installation length of electric heaters   Longueur maximale d'installation des chauffages électriques   Lunghezza massima di installazione dei riscaldatori elettrici	↑ – mm	-	630	630	630
		↓ – mm	-	520	520	520

\* Produktion auf Anfrage  
Production on Request | Production à la demande | Produzione su richiesta



mit Isolierung  
with insulation | avec isolation | con isolamento



Höhe  
Height | Hauteur | Altezza



Oben  
top | haut | superiore



Unten  
bottom | bas | parte inferiore

**Trinkwasserspeicher für Wärmepumpe**  
**Domestic hot water tank for heat pump**  
**Ballon eau chaude sanitaire pour pompe à chaleur**  
**Serbatoio di accumulo acqua calda sanitaria per pompa di calore**  
**WPS/E 300 – 2000**

**Emailliert**  
 Enamelled | Émaillés | Smaltato

**800 – 2000**

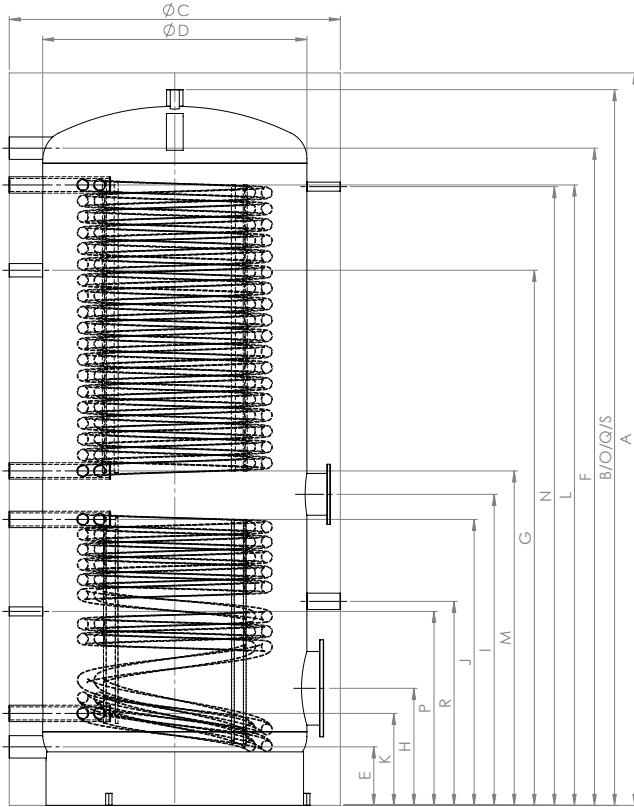

**800 – 2000**

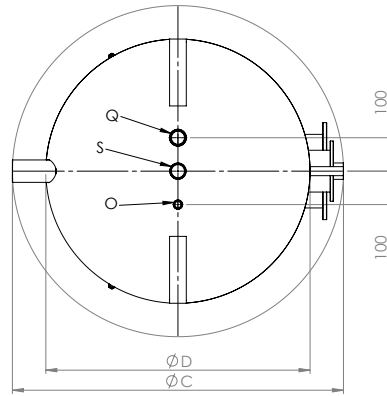

**800 – 2000**

- \* ACHTUNG: Magnesium Schutzanode
- \* ATTENTION Magnesium anode
- \* ATTENTION Anode de magnésium
- \* ATTENZIONE Anodo in magnesio



	Verwendung Usage Utilisation Uso	Dimension Dimension Dimension Dimensione	800	1000	1250	1500	1750	2000
A	Höhe Height   Hauteur   Altezza	⊙ – mm	1990	2190	2240	2120	2150	2350
B		○ – mm	1940	2140	2190	2070	2100	2300
C	Ø	⊙ – mm	990	990	1100	1200	1300	1300
D		○ – mm	790	790	900	1000	1100	1100
E	Kaltwasser Cold water   Eau froide   Acqua fredda	⇕ – mm	175	175	200	220	235	235
		G" – mm	2"	2"	2"	2"	2"	2"
F	Warmwasser Hot water   Eau chaude   Acqua calda	⇕ – mm	1765	1965	1990	1730	1730	1930
		G" – mm	2"	2"	2"	2"	2"	2"
G	Zirkulation Circulation   Circulation   Circolazione	⇕ – mm	1400	1600	1600	1450	1400	1650
		G" – mm	1"	1"	1"	1"	1"	1"
H	Flansch unten Flange below   Bride du bas   Flangia inferiore	⇕ – mm	350	350	400	470	480	480
		Ø – mm	290/220	290/220	290/220	290/220	290/220	290/220
I	Flansch oben Flange above   Bride du haut   Flangia superiore	⇕ – mm	800	930	900	850	870	1000
		Ø – mm	180/120	180/120	180/120	180/120	180/120	180/120
J	VL Glattröhrwärmetauscher unten Bottom heating coil   Échangeurs de chaleur bas   Serpentino inferiore	⇕ – mm	675	855	790	780	780	900
		G" – mm	1 ¼"	1 ¼"	1 ½"	1 ½"	1 ½"	1 ½"
K	RL Glattröhrwärmetauscher unten Bottom heating coil   Échangeurs de chaleur bas   Serpentino inferiore	⇕ – mm	275	275	320	360	360	360
		G" – mm	1 ¼"	1 ¼"	1 ½"	1 ½"	1 ½"	1 ½"
L	VL Glattröhrwärmetauscher oben Top heating coil   Échangeurs de chaleur haut   Serpentino superiore	⇕ – mm	1620	1855	1870	1600	1590	1790
		G" – mm	1 ¼"	1 ¼"	1 ½"	1 ½"	1 ½"	1 ½"
M	RL Glattröhrwärmetauscher oben Top heating coil   Échangeurs de chaleur haut   Serpentino superiore	⇕ – mm	900	1000	1020	910	940	1090
		G" – mm	1 ¼"	1 ¼"	1 ½"	1 ½"	1 ½"	1 ½"
N	Thermometer Thermometer   Thermomètre   Termometro	⇕ – mm	1650	1850	1900	1750	1750	1950
		G" – mm	½"	½"	½"	½"	½"	½"
O	Fühlerhülse Sensor sleeve   Manchon de sonde   Manicotto sensore	⇕ – mm	1940	2140	2190	2070	2100	2300
		G" – mm	½"	½"	½"	½"	½"	½"
P	Fühler Sensor   Sonde   Sensor	⇕ – mm	540	580	660	590	600	600
		G" – mm	½"	½"	½"	½"	½"	½"
Q	Magnesiumanode Magnesium anode   Anode de magnésium   Anodo in magnesio	⇕ – mm	1940	2140	2190	2070	2100	2300
		G" – mm	1 ¼"	1 ¼"	1 ¼"	1 ¼"	1 ¼"	1 ¼"
R	Magnesiumanode Magnesium anode   Anode de magnésium   Anodo in magnesio	⇕ – mm	570	610	670	1080	1110	730
		G" – mm	1 ¼"	1 ¼"	1 ¼"	1 ¼"	1 ¼"	1 ¼"
S	Anschluss oben Connection top   Lien ci-dessus   Collegamento sopra	⇕ – mm	1940	2140	2190*	2070*	2100*	2300*
		G" – mm	1 ¼"	1 ¼"	1 ¼"	1 ¼"	1 ¼"	1 ¼"
	Max. Einbaulänge von Elektroheizungen Maximum installation length of electric heaters   Longueur maximale d'installation des chauffages électriques   Lunghezza massima di installazione dei riscaldatori elettrici	⇑ – mm	800	800	920	1020	1120	1120
		⇓ – mm	620	620	690	800	900	900

